



# Intelligent Manual Pull Stations

E-270, E-278



## Overview

Edwards intelligent manual pull stations are engineered to deliver high-performance features, superb reliability, and unbeatable quality. From control of ancillary equipment, to enhanced signaling functionality, these products add flexibility and powerful options to Edwards Signaling intelligent systems.

Designed expressly for small buildings, Edwards Signaling pull stations are addressable modules that are uniquely identified on the system by means of familiar rotary switches. Once registered, they share data and update status information that determines how the system behaves and how connected devices interact with one another.

Edwards Signaling intelligent manual pull stations also offer contractors and installers simple setup and installation, while delivering options that take full advantage of intelligent fire alarm processing. With a microprocessor in each device, intelligence is distributed throughout the system so that command decisions are made instantly at the individual pull station, rather than bottlenecking at the control panel.

This not only speeds event processing, it also makes a more robust and reliable system – so robust, in fact, that when upgrading from a conventional panel to a Edwards Signaling intelligent system, you can usually use existing wiring – no twisted or shielded cable required!

## Standard Features

- Traditional familiar appearance**  
 Single action models feature our familiar teardrop design with simple positive pull action and sturdy die-cast metal body.
- Single action (GA) and double action models**  
 Double action feature rugged Lexan housings with keyed reset.
- Break glass operation**  
 An up-front visible glass rod on the E-270 discourages tampering.
- Intelligent device with integral microprocessor**  
 All decisions are made at the station allowing lower communication speed while substantially improving control panel response time. Less sensitive to line noise and loop wiring properties; twisted or shielded wire is not required.
- ADA Compliant**  
 Meets ADA requirements for manual pull stations.
- Rotary Addressing**  
 Familiar easy-to-set wheels.
- Diagnostic LEDs**  
 Status LEDs; flashing GREEN shows normal polling; flashing RED shows alarm state.
- Designed for high ambient temperature operation**  
 Install in ambient temperatures up to 120 °F (49 °C).

## Operation

A single input mini module mounted on the back of the unit (factory installed) supervises the station and sends an alarm signal to the control panel when the switch is closed (i.e. when the handle is pulled).

The device address is set using the two rotary switches located on the back of the unit. One device address is required.

The pull station is configured for alarm latching operation. When the pull lever is activated, an alarm signal is sent to the control panel and the alarm condition is latched at the pull station.

**The E-270 pull station** is a normally open dry contact initiating device that requires one action by the user to initiate an alarm.

**The E-278 pull station** is a normally open dry contact initiating device that requires two actions by the user to initiate an alarm. First, the upper door marked LIFT THEN PULL HANDLE must be raised to access the alarm handle. Second, the alarm handle must be pulled to initiate an alarm.

## Device Addressing

Use a screwdriver to adjust the two rotary switches on the front of the module. Set the TENS rotary switch (0 through 12) for the 10s digit and the ONES rotary switch for the 0 through 9 digit.

Insert screwdriver here

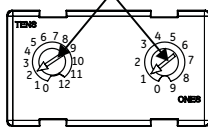

**Example:** device address 21, set TENS rotary switch to 2 and set the ONES rotary switch to 1.

Refer to the Specifications Table for available address numbers.

## Wiring

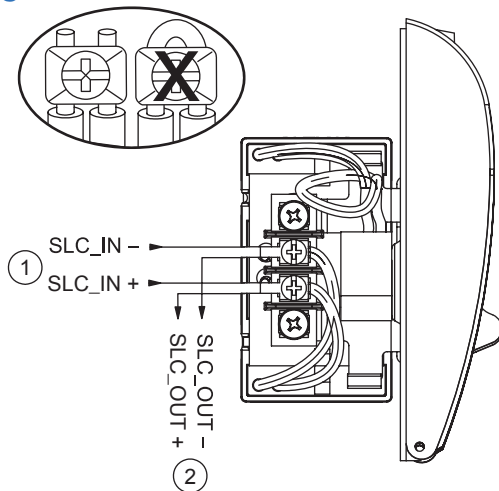

1. From previous device or control panel
2. To next device or EOL resistor

## Installation

Mount in a North American 2-1/2 in. (64 mm) deep 1 gang box, or standard 4 in. square box 1-1/2 in. (38 mm) deep box with 1 gang cover.

### E-270 Single Action Pull Station

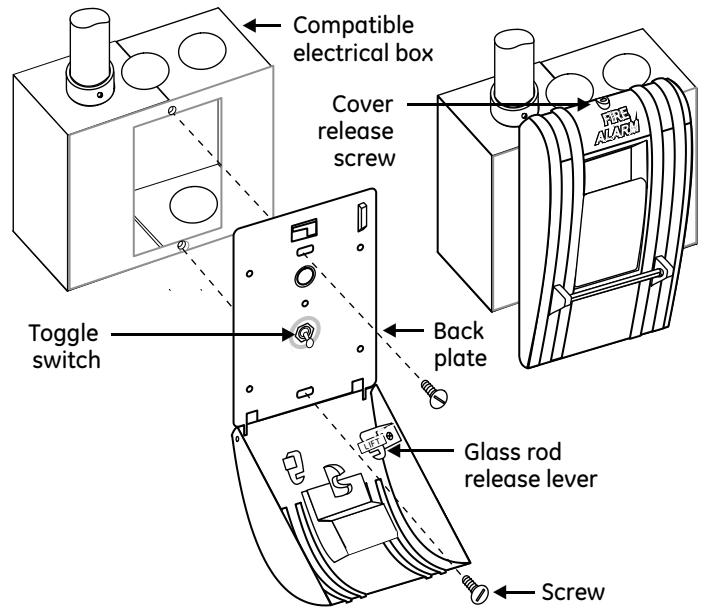

### E-278 Double Action Pull Station

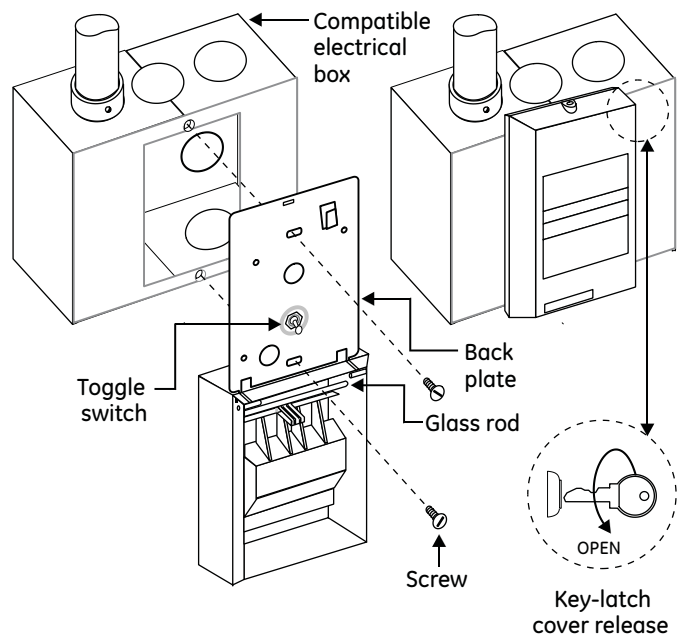

## Specifications

Communication line voltage	Maximum 20 V peak-to-peak
Current	
Standby	350 $\mu$ A
Activated	500 $\mu$ A
Operating environment	
Temperature	32 to 120°F (0 to 49°C)
Humidity	0 to 93% RH, noncondensing at 90°F (32°C)
Storage temperature range	-4 to 140°F (-20 to 60°C)
Compatible electrical boxes	North American 2-1/2 in. (64 mm) deep 1 gang box Standard 4 in. square box 1-1/2 in. (38 mm) deep box with 1 gang cover
Wire size	12, 14, 16, or 18 AWG wire (2.5, 1.5, 1.0, or 0.75 sq. mm) (Sizes 16 and 18 AWG are preferred)
Device address	01 to 64 (64 point control panel) 01 to 127 (127 point control panel)

## Ordering Information

Catalog Number	Description	Ship Wt. lbs (kg)
E-270	One Stage Fire Alarm Station	
E-278	Double Action Fire Alarm Station	1 (0.5)

### Accessories

276B-RSB	Surface Backbox, Red	0.1 (0.05)
276-K1	Station Reset Key, Supplied with all Key Reset Stations	0.1 (0.05)
27165	12 Glass Rods - for E-270 series (CANADA ONLY)	0.1 (0.05)
270-GLR	20 Glass Rods - for E-270 series (USA ONLY)	0.1 (0.05)
276-GLR	20 Glass Rods - for E-278 series	0.1 (0.05)

### Warning

These pull stations will not operate without electrical power. As fires frequently cause power interruption, you should discuss further safeguards with your local fire protection specialist.

### Caution

Wire in accordance with NFPA 72 and CAN/ULC-S524. Be sure to observe the polarity of the wires as shown in the diagram.



Contact us...

Phone: 1-800-336-4206

Web: [www.edwardssignaling.com](http://www.edwardssignaling.com)

Edwards Signaling is  
an **EDWARDS** brand.

3 Farm Glen Boulevard  
Farmington, CT 06032

In Canada, contact Chubb Edwards...

Email: [inquiries@chubbedwards.com](mailto:inquiries@chubbedwards.com)

Web: [www.chubbedwards.com](http://www.chubbedwards.com)

© 2013 UTC Fire & Security Americas  
Corporation, Inc. All rights reserved.  
Specifications subject to change  
without notice. Edwards is part of UTC  
Climate, Controls & Security, a unit of  
United Technologies Corporation.

---

## Overview

The Genesis line of signals are among the smallest, most compact audible-visible emergency signaling devices in the world. About the size of a deck of playing cards, these devices are designed to blend with any decor.

Thanks to patented breakthrough technology, GE Security Genesis strobes do not require bulky specular reflectors and lenses. Instead, an exclusive cavity design conditions light to produce a highly controlled distribution pattern. Significant development efforts employing this new technology have given rise to a new benchmark in strobe performance – FullLight technology.

FullLight strobe technology produces a smooth light distribution pattern without the spikes and voids characteristic of specular reflectors. This ensures the entire coverage area receives consistent illumination from the strobe flash. As a result, Genesis strobes with FullLight technology go well beyond the minimum UL-required “T” pattern, significantly exceeding UL-1971 and ULC-S526 light distribution requirements.

Genesis strobes and horn-strobes offer 15 to 110 candela output, which is selectable with a conveniently-located switch on the side of the device. Models are also available that offer fixed 15/75 cd output. The candela output setting remains clearly visible even after final installation, yet it stays locked in place to prevent unauthorized tampering.

Genesis signals feature textured housings in architecturally neutral white or traditional fire red. An ingenious iconographic symbol indicates the purpose of the device. This universal symbol is code-compliant and is easily recognized by all building occupants regardless of what language they speak. Models with “FIRE” markings are also available.

# Field Configurable Horns and Strobes

## Genesis Series



## Standard Features

- **Unique low-profile design**
  - The most compact UL-1971/ULC-S526 listed strobe available
  - Ultra-slim – protrudes less than one inch
  - Attractive appearance
  - No visible mounting screws
- **Four field-configurable options in one device**
  - Select 15, 30, 75, or 110 cd strobe output
  - Select high (default) or low dB horn output
  - Select temporal (default) or steady horn output
  - Select public mode flash rate (default) or private mode temporal flash
- **Fixed 15/75 cd model available**
- **Easy to install**
  - Fits standard 1-gang electrical boxes – no trim plate needed
  - Optional trim plate accommodates oversized openings
  - Pre-assembled with captive hardware
  - #12 AWG terminals – ideal for long runs or existing wiring
- **Unparalleled performance**
  - Industry’s most even light distribution
  - Meets tough synchronizing standards for strobes
  - Single microprocessor controls both horn and strobe
  - Low current draw minimizes system overhead
  - Independent horn control over a single pair of wires
  - Highly regulated in-rush current
  - Multiple frequency tone improves sound penetration
  - Industry’s first temporal strobe output

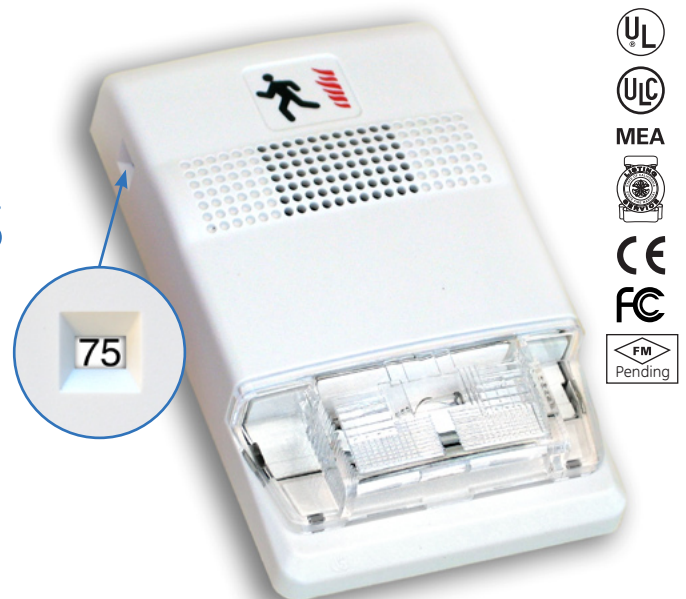

## Application

Genesis strobes are UL 1971-listed for use indoors as wall-mounted public-mode notification appliances for the hearing impaired. Prevailing codes require strobes to be used where ambient noise conditions exceed 105 dBA (87dBA in Canada), where occupants use hearing protection, and in areas of public accommodation as defined in the *Americans with Disabilities Act* (see application notes – USA).

Combination horn-strobe signals must be installed in accordance with guidelines established for strobe devices.

### Strobes

Genesis strobes are UL 1971-listed for use indoors as wall-mounted public-mode notification appliances for the hearing impaired. Prevailing codes require strobes to be used where ambient noise conditions exceed specified levels, where occupants use hearing protection, and in areas of public accommodation. Consult with your Authority Having Jurisdiction for details.

All Genesis strobes exceed UL synchronization requirements (within 10 milliseconds other over a two-hour period) when used with a synchronization source. Synchronization is important in order to avoid epileptic sensitivity.

**NOTE:** The flash intensity of some visible signals may not be adequate to alert or waken occupants in the protected area. Research indicates that the intensity of strobe needed to awaken 90% of sleeping persons is approximately 100 cd. GE Security recommends that strobes in sleeping rooms be rated at at least 110 cd.

**WARNING:** These devices will not operate without electrical power. As fires frequently cause power interruptions, further safeguards such as backup power supplies may be required.

### Horns

Genesis horn output reaches as high as 99 dB and features a unique multiple frequency tone that results in excellent sound penetration and an unmistakable warning of danger. Horns may be configured for either coded or non-coded signal circuits. They can also be set for low dB output with a jumper cut that reduces horn output by about 5 dB. Horn-only models may be ceiling-mounted or wall-mounted.

The suggested sound pressure level for each signaling zone used with alert or alarm signals is at least 15 dB above the average ambient sound level, or 5 dB above the maximum sound level having a duration of at least 60 seconds, whichever is greater, measured 5 feet (1.5 m) above the floor. The average ambient sound level is, A-weighted sound pressure measured over a 24-hour period.

Doubling the distance from the signal to the ear will theoretically result in a 6 dB reduction of the received sound pressure level. The actual effect depends on the acoustic properties of materials in the space. A 3 dBA difference represents a barely noticeable change in volume.

## Installation

Genesis horns and strobes mount to any standard one-gang surface or flush electrical box. Matching optional trim plates are used to cover oversized openings and can accommodate one-gang, two-gang, four-inch square, or octagonal boxes, and European 100 mm square.



Genesis Horn/Strobe with optional trim plate

All Genesis signals come pre-assembled with captive mounting screws for easy installation. Two tabs at the top of the signal unlock the cover to reveal the mounting hardware. The shallow depth of Genesis devices leaves ample room behind the signal for extra wiring. Once installed with the cover in place, no mounting screws are visible.

### Field Configuration

Temporal horn and horn-strobe models are factory set to sound in a **three-pulse temporal pattern**. Units may be configured for use with coded systems by cutting a jumper on the circuit board. This results in a **steady output** that can be turned on and off (coded) as the system applies and removes power to the signal circuit. A Genesis Signal Master is required when horn-strobe models are configured for coded systems. Non-temporal, horn-only models sound a steady tone.

Genesis strobes and horn-strobes are shipped from the factory ready for use as **UL 1971 compliant** signals for public mode operation. These signals may be configured for **temporal flash** by cutting a jumper on the circuit board. This battery-saving feature is intended for private mode signaling only.

Genesis strobes and horn-strobes may be set for **15, 30, 75, or 110 candela output**. The output setting is changed by simply opening the device and sliding the switch to the desired setting. The device does not have to be removed to change the output setting. The setting remains visible through a small window on the side of the device after the cover is closed.

Horns and horn-strobes are factory set for **high dB output**. **Low dB output** may be selected by cutting a jumper on the circuit board. This reduces the output by about 5 dB.

## Wiring

Field wiring terminals accommodate #18 to #12 AWG (0.75 mm<sup>2</sup> to 2.5 mm<sup>2</sup>) wiring. Horns, strobes, and combination horn-strobes are interconnected with a single pair of wires as shown below.

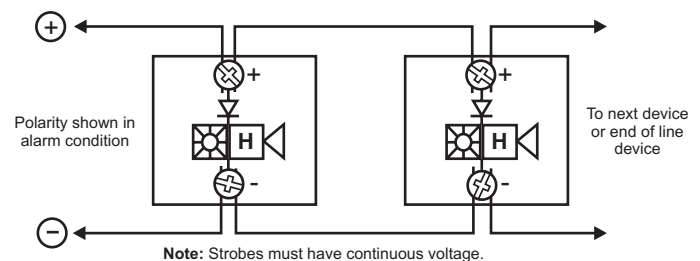

# Current Draw

## Strobes, Horn-Strobes

### Multi-cd Wall Strobes (G1-VM)

UL Rating	15 cd*	30 cd*	15/75 cd**	75 cd*	110 cd*
	RMS	RMS	RMS	RMS	RMS
16 Vdc	103	141	152	255	311
16 Vfwr	125	179	224	346	392

\*G1-VM multi-cd; \*\*G1F-V1575 fixed 15/75 cd

Typical Current	15 cd		30 cd		15/75		75 cd		110 cd	
	RMS	Mean	RMS	Mean	RMS	Mean	RMS	Mean	RMS	Mean
16 Vdc	85	79	127	124	150	140	245	243	285	283
20 Vdc	71	66	98	96	123	114	188	186	240	238
24 Vdc	59	55	82	80	104	97	152	150	191	190
33 Vdc	46	44	64	63	84	77	112	111	137	136
16 Vfwr	119	64	169	97	223	126	332	203	376	240
20 Vfwr	103	51	143	76	189	100	253	150	331	198
24 Vfwr	94	44	129	65	169	85	218	121	262	152
33 Vfwr	87	37	112	52	148	68	179	89	205	106

### Wall Temporal Horn-strobes – High dB Setting

UL Rating	15 cd*	30 cd*	15/75 cd**	75 cd*	110 cd*	*G1-HDVM multi-cd **G1F-HDV1575 fixed 15/75 cd
	RMS	RMS	RMS	RMS	RMS	
16 Vdc	129	167	172	281	337	
16 Vfwr	176	230	269	397	443	

Typical Current	15 cd		30 cd		15/75		75 cd		110 cd	
	RMS	Mean	RMS	Mean	RMS	Mean	RMS	Mean	RMS	Mean
16 Vdc	102	89	135	129	160	152	246	242	309	305
20 Vdc	88	77	109	104	137	129	193	190	248	243
24 Vdc	81	71	94	90	122	114	161	158	203	200
33 Vdc	74	64	72	74	106	98	124	121	154	151
16 Vfwr	144	77	182	106	247	143	352	212	393	249
20 Vfwr	141	68	162	87	220	120	274	158	362	210
24 Vfwr	136	65	152	76	203	106	235	133	282	165
33 Vfwr	125	54	144	65	196	94	201	101	232	123

### Wall Temporal Horn-strobes – Low dB Setting

UL Rating	15 cd*	30 cd*	15/75 cd**	75 cd*	110 cd*	*G1-HDVM multi-cd **G1F-HDV1575 fixed 15/75 cd
	RMS	RMS	RMS	RMS	RMS	
16 Vdc	122	160	146	274	330	
16 Vfwr	162	216	231	383	429	

Typical Current	15 cd		30 cd		15/75		75 cd		110 cd	
	RMS	Mean	RMS	Mean	RMS	Mean	RMS	Mean	RMS	Mean
16 Vdc	96	84	130	124	158	149	243	240	302	297
20 Vdc	79	70	104	99	133	124	189	186	241	237
24 Vdc	68	61	88	84	119	110	156	154	197	193
33 Vdc	56	52	71	68	100	93	118	116	146	143
16 Vfwr	128	69	180	104	241	139	344	204	389	244
20 Vfwr	118	60	157	84	213	115	266	156	343	200
24 Vfwr	113	54	144	74	195	101	230	128	279	161
33 Vfwr	112	48	137	64	182	87	197	99	226	117

## Horns

### Wall or Ceiling Mounted Temporal Horns (G1-HD)

UL Rating	High dB (RMS)	Low dB (RMS)
16 Vdc	26	19
24 Vdc	36	27
33 Vdc	41	33
16 Vfwr	51	37
24 Vfwr	69	52
33 Vfwr	76	70

Typical Current	High dB		Low dB	
	RMS	Mean	RMS	Mean
16 Vdc	22	17	17	14
20 Vdc	24	19	19	16
24 Vdc	27	21	22	18
33 Vdc	32	25	26	22
16 Vfwr	34	15	30	14
20 Vfwr	40	19	34	16
24 Vfwr	45	21	38	18
33 Vfwr	52	24	47	22

### Wall or Ceiling Mounted Horns (G1-P)

UL Designation	Voltage Range	Max. Current, RMS
Regulated 24 Vdc	16 - 33 Vdc	13 mA
24 fwr	16 - 33 Vfwr	11 mA

Typical Current	RMS	Mean
24 Vdc	10	10
24 Vdc	11	11
31 Vdc	12	12
20 Vfwr	9	8
24 Vfwr	10	9

### Notes and Comments

- Current values are shown in mA.
- UL Nameplate Rating can vary from Typical Current due to measurement methods and instruments used.
- GE Security recommends using the Typical Current for system design including NAC and Power Supply loading and voltage drop calculations.
- Use the Vdc RMS current ratings for filtered power supply and battery AH calculations. Use the Vfwr RMS current ratings for unfiltered power supply calculations.
- Fuses, circuit breakers and other overcurrent protection devices are typically rated for current in RMS values. Most of these devices operate based upon the heating affect of the current flowing through the device. The RMS current (not the mean current) determines the heating affect and therefore, the trip and hold threshold for those devices.
- Our industry has used 'mean' currents over the years. However, UL will direct the industry to use the 2004 RMS values in the future.

## dBA output

### Temporal Horns, Horn-strobes (G1-HD, G1-HDVM series)

High dB Setting	UL464		Average	Peak
	Temporal	Steady	Temporal/ Steady	Temporal/ Steady
16 Vdc	81.4	85.5	91.4	94.2
24 Vdc	84.4	88.6	94.5	97.6
33 Vdc	86.3	90.4	96.9	99.5

Low dB Setting	UL464		Average	Peak
	Temporal	Steady	Temporal/ Steady	Temporal/ Steady
16 Vdc	76.0	80.1	86.3	89.2
24 Vdc	79.4	83.5	89.8	92.5
33 Vdc	82.1	86.5	92.5	95.3

### Steady Tone Horns (G1-P series)

	UL464	Average	Peak
16 Vdc	77 dBA, min	85 dBA	91 dBA
16 Vfwr	77 dBA, min	85 dBA	91 dBA

#### Notes

1. All values shown are dBA measured at 10 feet (3.01m).
2. UL464 values measured in reverberation room.
3. Average and Peak values are measured in anechoic chamber.

## Average Sound Output (dBA)

(High dB setting, anechoic, 24V, measured at 10ft)

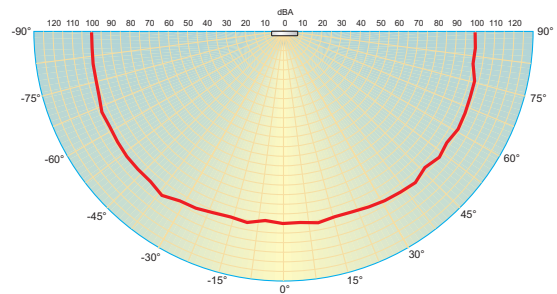

## Light output - (effective cd)

Percent of UL rating versus angle

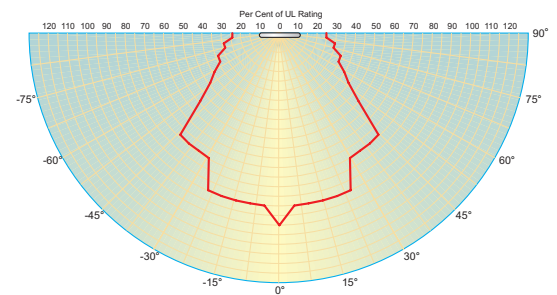

## Specifications

Housing	Red or white textured UV stabilized, color impregnated engineered plastic. Exceeds 94V-0 UL flammability rating.
Lens	Optical grade polycarbonate (clear)
Mounting (indoor only)	Strobes and horn-strobes are for wall-mount installation only. Horn-only models may be ceiling- or wall-mounted. Flush mount: 2½ inch (64 mm) deep one-gang box Surface mount: Model 27193 surface mount box, wiremold box, or equivalent surface-mount box With optional trim plate: One-gang, two-gang, four-inch square, octagonal, or European single-gang box
Wire connections	Screw terminals: single input for both horn and strobe. #18 to #12 AWG (0.75 mm <sup>2</sup> to 2.5 mm <sup>2</sup> ) wire size
Operating environment	Indoor only: 32-120°F (0-49°C) ambient temperature. 93% relative humidity
Agency listings/approvals	UL 1971, UL 1638, UL 464, ULC S525, ULC S526, CSFM, CE, FCC, MEA (FM pending). (All models comply with ADA Code of Federal Regulation Chapter 28 Part 36 Final Rule.)
Dimensions (HxWxD)	Signal: 4-1/2" x 2-3/4" x 13/16" (113 mm x 68 mm x 21 mm) Trimplate: 5" (127 mm); Height - 5-7/8" (149 mm); Depth - ½" (13 mm)
Operating voltage	G1-HD series temporal-tone horns: non-coded, filtered 16-33 Vdc or unfiltered 16-33 Vdc FWR (or coded when horn set to steady tone) G1-HDVM series temporal-tone horn-strobes: non-coded, filtered 16-33 Vdc or unfiltered 16-33 Vdc FWR (or coded (audible NAC only) when used with optional G1M Genesis Signal Master) G1-VM series strobes: non-coded, filtered 16 - 33 Vdc or unfiltered 16-33 Vdc FWR G1-P series steady-tone horns: coded or non-coded, filtered 20-31 Vdc or unfiltered 20-27 Vfwr
Strobe output rating	UL 1971, UL 1638, ULC S526: selectable 15 cd, 30 cd, 75 cd, or 110 cd output UL 1971: 15 cd (fixed 15/75 cd models) UL 1638, ULC S526: 75 cd (fixed 15/75 cd models)
Strobe flash rate	G1-VM strobes and G1-HDVM series temporal-tone horn-strobes: one flash per second synchronized with optional G1M Genesis Signal Master indefinitely within 10 milliseconds (or self-synchronized within 200 milliseconds over thirty minutes on a common circuit without G1M Genesis Signal Master) Temporal setting (private mode only): synchronized to temporal output of horns on same circuit
Synchronization Sources	G1M, G1M-RM, SIGA-CC1S, SIGA-MCC1S, BPS6A, BPS10A
Horn pulse rate	G1-HD temporal-tone horns and G1-HDVM series temporal-tone horn-strobes: temporal rate synchronized with optional G1M Genesis Signal Master indefinitely within 10 milliseconds (or self-synchronized within 200 milliseconds over thirty minutes on a common circuit without G1M Genesis Signal Master) G1-P steady-tone horns: continuous, steady tone only
Temporal audible pattern	½ sec ON, ½ sec OFF, ½ sec ON, ½ sec OFF, ½ sec ON, 1½ sec OFF, then repeat cycle



## Ordering Information

Catalog Number		Description	Ship Wt. lbs (kg)
White Finish	Red Finish		
G1-HDVM	G1R-HDVM	Genesis Horn-Strobe (selectable 15, 30, 75, or 110 cd output, selectable high/low dB output)	0.25 (0.11)
G1-VM	G1R-VM	Genesis Strobe (selectable 15, 30, 75, or 110 cd output)	
G1-HD	G1R-HD	Genesis Temporal Horn (selectable high/low dB output)	
G1-P	G1R-P	Genesis Steady Horn (not compatible with Genesis Signal Master)	
G1F-HDVM	G1RF-HDVM	Genesis Horn-Strobe (selectable 15, 30, 75, or 110 cd output, selectable high/low dB output) – with “FIRE” marking	
G1F-VM	G1RF-VM	Genesis Strobe (selectable 15, 30, 75, or 110 cd output) – with “FIRE” marking	
G1F-HD	G1RF-HD	Genesis Temporal Horn (selectable high/low dB output) – with “FIRE” marking	
G1F-P	G1RF-P	Genesis Steady Horn with “FIRE” marking (not compatible with Genesis Signal Master)	
G1F-HDV1575	G1RF-HDV1575	15/75 cd temporal horn-strobe, hi/lo dB-24V – with “FIRE” marking (see note 1)	
G1F-V1575	G1RF-V1575	15/75 cd strobe – with “FIRE” marking (see note 1)	

### Mounting Accessories

G1T	G1RT	Genesis Trim Plate (for two-gang or 4” square boxes)	0.15 (0.7)
G1T-FIRE	G1RT-FIRE	Genesis Trim Plate (for two-gang or 4” square boxes) with “FIRE” markings	0.15 (0.7)
27193-16	27193-11	One-gang surface mount box	1 (0.4)

### Synchronization Modules

G1M	Genesis Signal Master – Snap-on Mount		0.2 (0.1)
G1M-RM	Genesis Signal Master – Remote Mount (1-gang)		
SIGA-CC1S	Intelligent Synchronization Output Module (2-gang)		0.5 (0.23)
SIGA-MCC1S	Intelligent Synchronization Output Module (Plug-in UIO)		0.18 (0.08)

**Note 1:** These 15/75 cd models provide fixed output and are not multi-candela devices. The 15 cd output component complies with UL1971, while the 75 cd output component complies with UL 1638.



Genesis Horn-Strobes may be ordered in red or white, with or without ‘FIRE’ marking. Order matching trim plates separately.

# GE Security

U.S.  
T 888-378-2329  
F 866-503-3996

Canada  
T 519 376 2430  
F 519 376 7258

Asia  
T 852 2907 8108  
F 852 2142 5063

Australia  
T 61 3 9259 4700  
F 61 3 9259 4799

Europe  
T 32 2 725 11 20  
F 32 2 721 86 13

Latin America  
T 305 593 4301  
F 305 593 4300

[www.gesecurity.com/est](http://www.gesecurity.com/est)

© 2007 General Electric Company  
All Rights Reserved.

Genesis Series is a trademark of GE Security.



imagination at work



# Control Relay Modules

SIGA-CR, SIGA-MCR, SIGA-CRR, SIGA-MCRR



SIGA-MCR

## Overview

The Control Relay Module and the Polarity Reversal Relay Module are part of the Signature Series system. They are intelligent analog addressable devices available in either plug-in (UIO) versions, or standard 1-gang mount versions.

**The SIGA-CR/MCR** Control Relay Module provides a Form “C” dry relay contact to control external appliances such as door closers, fans, dampers etc. This device does not provide supervision of the state of the relay contact. Instead, the on-board micro-processor ensures that the relay is in the proper ON/OFF state. Upon command from the loop controller, the SIGA-CR/MCR relay activates the normally open or normally-closed contact.

**The SIGA-CRR/MCRR** Polarity Reversal Relay Module provides a Form “C” dry relay contact to power and activate a series of SIGA-AB4G Audible Sounder Bases. Upon command from the Signature loop controller, the SIGA-CRR reverses the polarity of its 24 Vdc output, thus activating all Sounder Bases on the data loop.

**Standard-mount versions (SIGA-CR and SIGA-CRR)** are installed to standard North American 1-gang electrical boxes, making them ideal for locations where only one module is required. Separate I/O and data loop connections are made to each module.

**Plug-in UIO versions (SIGA-MCR and SIGA-MCRR)** are part of the UIO family of plug-in Signature Series modules. They function identically to the standard mount versions, but take advantage of the modular flexibility and easy installation that characterizes all UIO modules. Two- and six-module UIO motherboards are available. All wiring connections are made to terminal blocks on the motherboard. UIO assemblies may be mounted in Edwards enclosures.

## Standard Features

- Provides one no/nc contact (SIGA-CR/MCR)**  
 Form “C” dry relay contact can be used to control external appliances such as door closers, fans, dampers etc.
- Allows group operation of sounder bases**  
 The SIGA-CRR/MCRR reverses the polarity of its 24 Vdc output, thus activating all Sounder Bases on the data loop.
- Plug-in (UIO) or standard 1-gang mount**  
 UIO versions allow quick installation where multiple modules are required. The 1-gang mount version is ideal for remote locations that require a single module.
- Automatic device mapping**  
 Signature modules transmit information to the loop controller regarding their circuit locations with respect to other Signature devices on the wire loop.
- Electronic addressing**  
 Programmable addresses are downloaded from the loop controller, a PC, or the SIGA-PRO Signature Program/Service Tool; there are no switches or dials to set.
- Intelligent device with microprocessor**  
 All decisions are made at the module to allow lower communication speed with substantially improved control panel response time and less sensitivity to line noise and loop wiring properties; twisted or shielded wire is not required.
- Ground fault detection by address**  
 Detects ground faults right down to the device level.

## Installation

**SIGA-CR and SIGA-CRR:** modules mount to North American 2½ inch (64 mm) deep 1-gang boxes and 1½ inch (38 mm) deep 4 inch square boxes with 1-gang covers and SIGA-MP mounting plates. The terminals are suited for #12 to #18 AWG (2.5 mm<sup>2</sup> to 0.75 mm<sup>2</sup>) wire size.

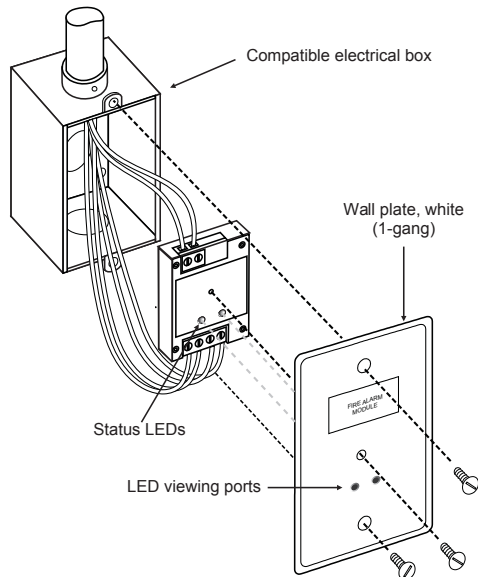

**SIGA-MCR and SIGA-MCRR:** mount the UIO motherboard inside a suitable Edwards enclosure with screws and washers provided. Plug the module into any available position on the motherboard and secure the module to the motherboard with the captive screws. Wiring connections are made to the terminals on the motherboard (see wiring diagram). UIO motherboard terminals are suited for #12 to #18 AWG (2.5 mm<sup>2</sup> to 0.75 mm<sup>2</sup>) wire size.

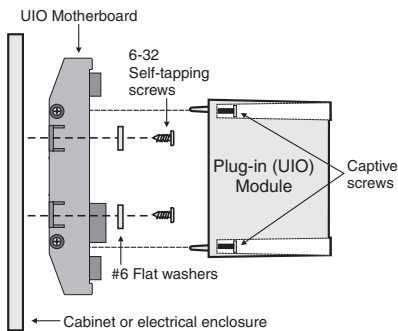

**Electronic Addressing** - The loop controller electronically addresses each module, saving valuable time during system commissioning. Setting complicated switches or dials is not required. Each module has its own unique serial number stored in its on-board memory. The loop controller identifies each device on the loop and assigns a “soft” address to each serial number. If desired, the modules can be addressed using the SIGA-PRO Signature Program/Service Tool.

Edwards recommends that this module be installed according to latest recognized edition of national and local fire alarm codes.

## Application

The operation of Signature Series control relays is determined by their sub-type code or “Personality Code.”

**Personality Code 8: CONTROL RELAY (SIGA-CR/MCR) - Dry Contact Output.** This setting configures the module to provide one Form “C” DRY RELAY CONTACT to control Door Closers, Fans, Dampers, etc. Contact rating is 2.0 amp @ 24 Vdc; 0.5 amp @ 120 Vac (or 220 Vac for non-UL applications). Personality Code 8 is assigned at the factory. No user configuration is required.

**Personality Code 8: POLARITY REVERSAL RELAY MODULE (SIGA-CRR/MCRR).** This setting configures the module to reverse the polarity of its 24 Vdc output. Contact rating is 2.0 amp @ 24 Vdc (pilot duty). Personality Code 8 is assigned at the factory. No user configuration is required.

## Compatibility

The Signature Series modules are compatible only with EST's Signature Loop Controller.

## Warnings & Cautions

This module will not operate without electrical power. As fires frequently cause power interruption, we suggest you discuss further safeguards with your local fire protection specialist.

## Testing & Maintenance

The module's automatic self-diagnosis identifies when it is defective and causes a trouble message. The user-friendly maintenance program shows the current state of each module and other pertinent messages. Single modules may be turned off (deactivated) temporarily, from the control panel. Availability of maintenance features is dependent on the fire alarm system used. Scheduled maintenance (Regular or Selected) for proper system operation should be planned to meet the requirements of the Authority Having Jurisdiction (AHJ). Refer to current NFPA 72 and ULC CAN/ULC 536 standards.

## Typical Wiring

Modules will accept #18 AWG (0.75mm<sup>2</sup>), #16 (1.0mm<sup>2</sup>), #14 AWG (1.50mm<sup>2</sup>) and #12 AWG (2.5mm<sup>2</sup>) wire sizes.

Note: Sizes #16 AWG (1.0mm<sup>2</sup>) and #18 AWG (0.75mm<sup>2</sup>) are preferred for ease of installation. See Signature Loop Controller catalog sheet for detailed wiring requirement specifications.

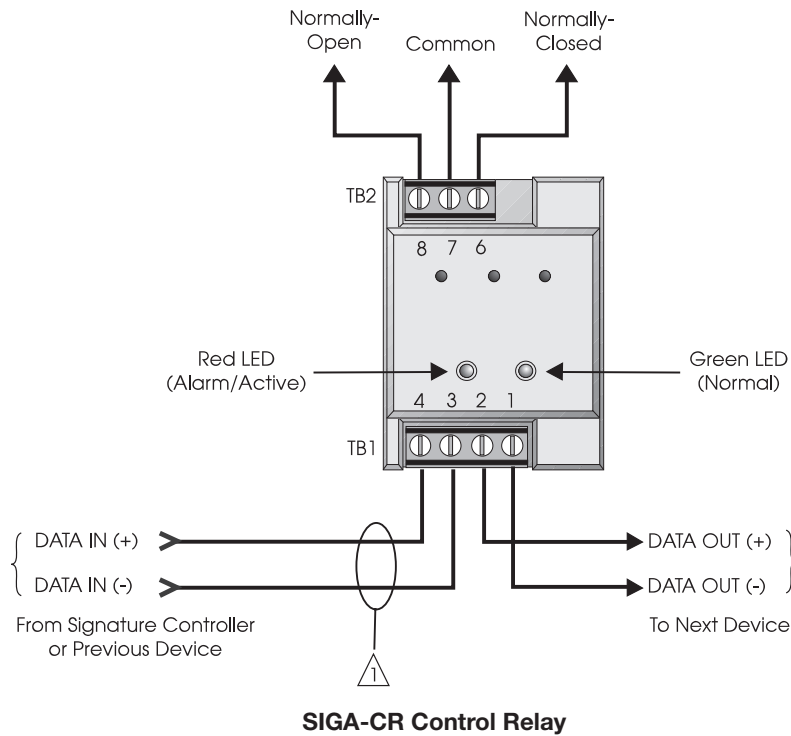

### Notes

- 1) Refer to Signature Loop Controller Installation Sheet for wiring specifications.
- 2) NFPA 72 requires that the SIGA-CR/SIGA-MCR be installed in the same room as the device it is controlling. This requirement may not apply in all markets. Check with your local AHJ for details.
- 3) The SIGA-UIO6R and the SIGA-UIO2R do not come with TB14.
- 4) The SIGA-UIO6 does not come with TB8 through TB13.
- 5) Supervised and power-limited.
- 6) If the source is nonpower-limited, maintain a space of 1/4 inch from power-limited wiring or use FPL, FPLP, FPLR, or an equivalent in accordance with the National Electrical Code.
- 7) Maximum #12 AWG (2.5mm<sup>2</sup>) wire. Min. #18 (0.75mm<sup>2</sup>).

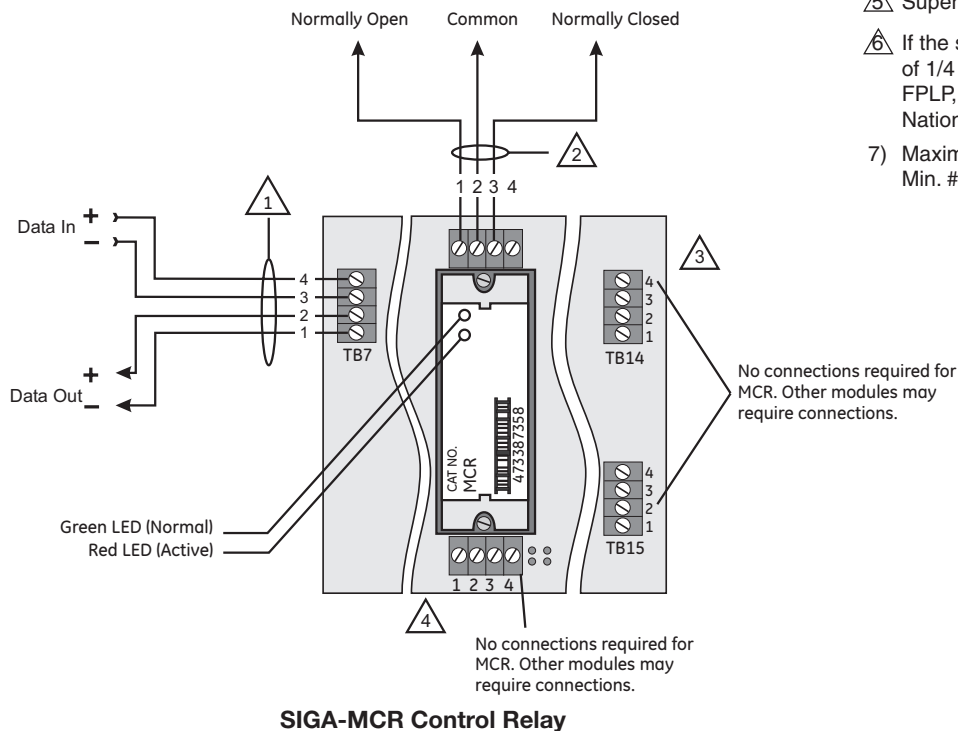

# Typical Wiring

Modules will accept #18 AWG (0.75mm<sup>2</sup>), #16 (1.0mm<sup>2</sup>), #14 AWG (1.50mm<sup>2</sup>) and #12 AWG (2.50mm<sup>2</sup>) wire sizes.

Note: Sizes #16 AWG (1.0mm<sup>2</sup>) and #18 AWG (0.75mm<sup>2</sup>) are preferred for ease of installation. See Signature Loop Controller catalog sheet for detailed wiring requirement specifications.

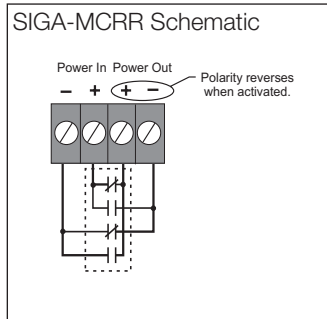
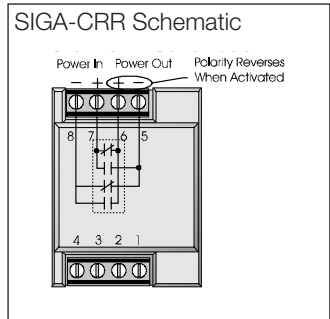
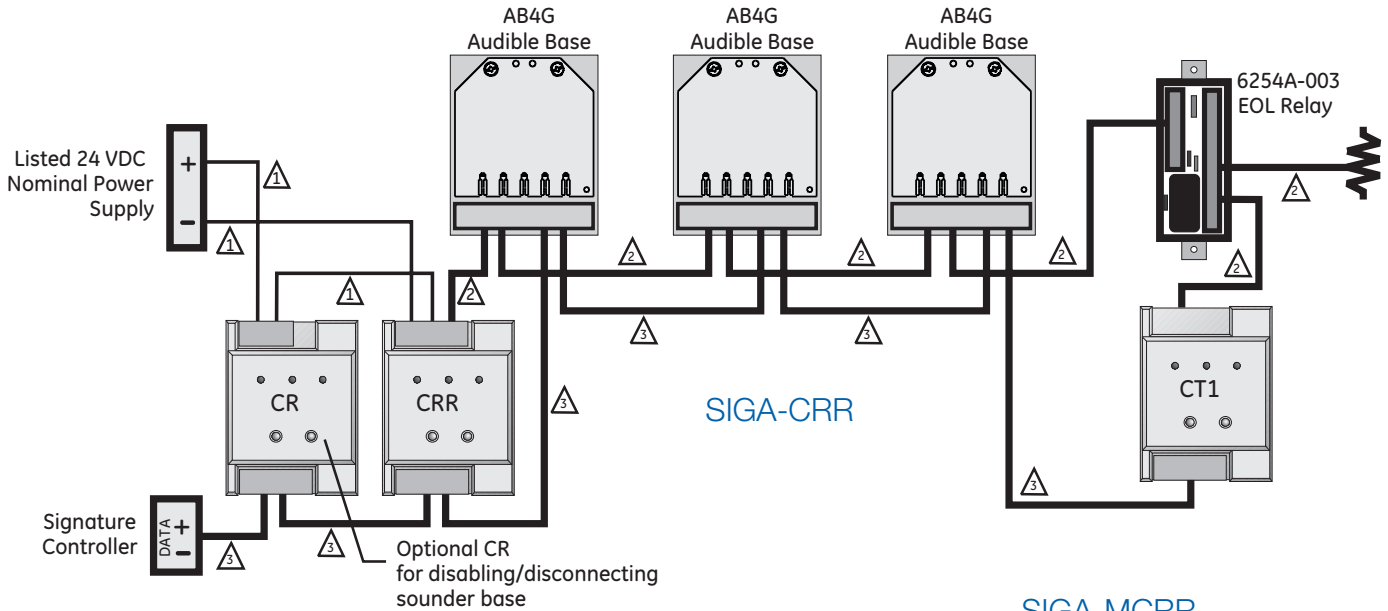

## Notes

- ⚠ Refer to the Signature controller installation sheet for wiring.
- ⚡ One Pair of Wires (24 Vdc power).
- ⚡ One Pair of Wires (Signature Data).
- ⚡ Single Wire (24 Vdc power).
- ⚠ The SIGA-UIO6R and the SIGA-UIO2R do not come with TB14.
- ⚠ The SIGA-UIO6 does not come with TB8 through TB13.
- ⚠ Supervised and power-limited.
- 8 If the source is nonpower-limited, maintain a space of 1/4 inch from power-limited wiring or use FPL, FPLP, FPLR, or an equivalent in accordance with the National Electrical Code.
- 9 Maximum #12 AWG (2.5 mm<sup>2</sup>) wire; Minimum #18 AWG (0.75 mm<sup>2</sup>).
- 10 End-of-Line Relay must monitor and report power supply trouble to control panel.
- 11 Class B Data wiring may be "T-tapped."

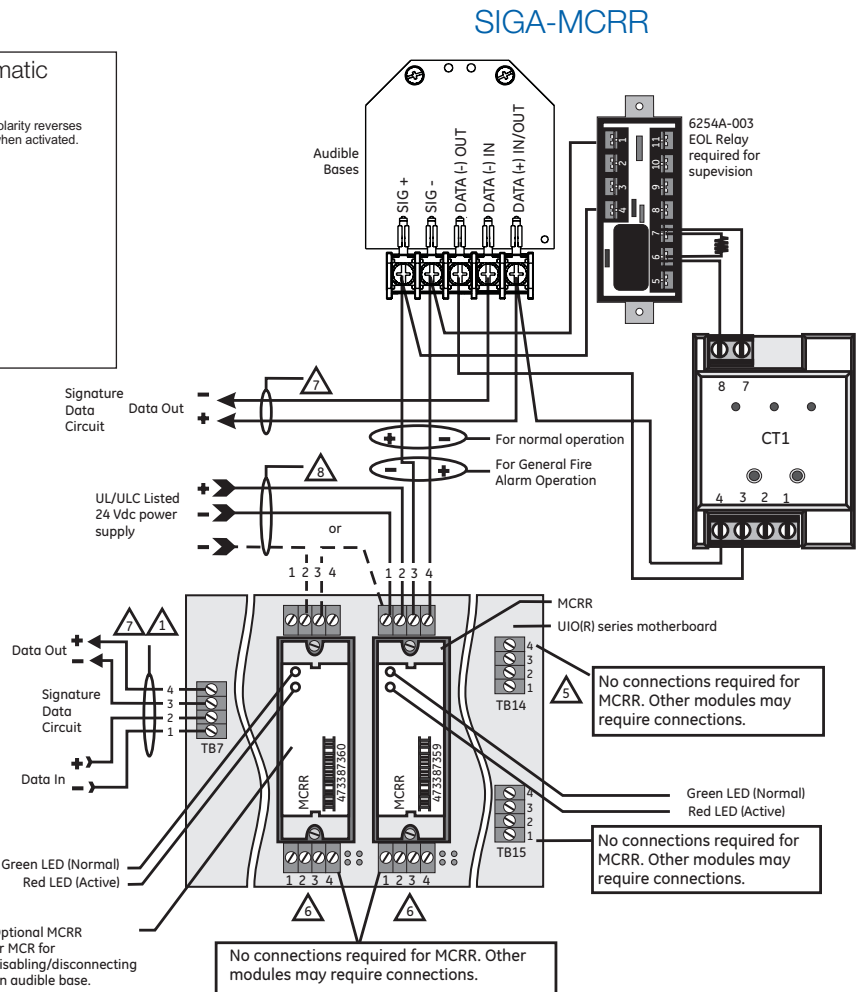

## Specifications

Catalog Number	SIGA-CR	SIGA-MCR	SIGA-CRR	SIGA-MCRR
Description	Control Relay		Polarity Reversal Relay	
Type Code	Personality Code 8 (Factory Set)		Personality Code 8 (Factory Set)	
Address Requirements	Uses 1 Module Address			
Operating Current	Standby = 100µA Activated = 100µA			
Operating Voltage	15.2 to 19.95 Vdc (19 Vdc nominal)			
Relay Type and Rating	Form "C" 24 VDC = 2 amps (pilot duty) 120 Vac = 0.5 amps 220 Vac (non-UL) = 0.5 amps			
Mounting	North American 2½ inch (64 mm) deep 1-gang boxes and 1½ inch (38 mm) deep 4 inch square boxes with 1-gang covers and SIGA-MP mounting plates	Plugs into UIO2R, UIO6R or UIO6 Motherboards	North American 2½ inch (64 mm) deep 1-gang boxes and 1½ inch (38 mm) deep 4 inch square boxes with 1-gang covers and SIGA-MP mounting plates	Plugs into UIO2R, UIO6R or UIO6 Motherboards
Construction & Finish	High Impact Engineering Polymer			
Storage and Operating Environment	Operating Temperature: 32°F to 120°F (0°C to 49°C) Storage Temperature: -4°F to 140°F (-20°C to 60°C) Humidity: 0 to 93% RH			
LED Operation	On-board Green LED - Flashes when polled On-board Red LED - Flashes when in alarm/active			
Compatibility	Use With: Signature Loop Controller			
Agency Listings	UL, ULC, CSFM, MEA			

## Ordering Information

Catalog Number	Description	Ship Weight - lbs (kg)
SIGA-CR	Control Relay Module (Standard Mount)	0.4 (0.15)
SIGA-MCR	Control Relay Module (UIO Mount)	0.18 (0.08)
SIGA-CRR	Polarity Reversal Relay Module (Standard Mount)	0.4 (0.15)
SIGA-MCRR	Polarity Reversal Relay Module (UIO Mount)	0.18 (0.08)

### Related Equipment

27193-11	Surface Mount Box - Red, 1-gang	1 (0.6)
27193-16	Surface Mount Box - White, 1-gang	1 (0.6)
SIGA-UIO2R	Universal Input-Output Module Board w/Riser Inputs - Two Module Positions	0.32 (0.15)
SIGA-UIO6R	Universal Input-Output Module Board w/Riser Inputs - Six Module Positions	0.62 (0.28)
SIGA-UIO6	Universal Input-Output Module Board - Six Module Positions	0.56 (0.25)
SIGA-AB4G	Audible (Sounder) Detector Base	0.3 (0.15)

### Accessories

MFC-A	Multifunction Fire Cabinet - Red, supports Signature Module Mounting Plates	7.0 (3.1)
SIGA-MB4	Transponder Mounting Bracket (allows for mounting two 1-gang modules in a 2-gang box)	0.4 (0.15)
SIGA-MP1	Signature Module Mounting Plate, 1 footprint	1.5 (0.70)
SIGA-MP2	Signature Module Mounting Plate, 1/2 footprint	0.5 (0.23)
SIGA-MP2L	Signature Module Mounting Plate, 1/2 extended footprint	1.02 (0.46)



**Detection & alarm since 1872**

U.S.  
T 888-378-2329  
F 866-503-3996

Canada  
Chubb Edwards  
T 519 376 2430  
F 519 376 7258

Southeast Asia  
T : +65 6391 9300  
F : +65 6391 9306

India  
T : +91 80 4344 2000  
F : +91 80 4344 2050

Australia  
T +61 3 9239 1200  
F +61 3 9239 1299

Europe  
T +32 2 725 11 20  
F +32 2 721 86 13

Latin America  
T 305 593 4301  
F 305 593 4300

utcfireandsecurity.com

© 2010 UTC Fire & Security.  
All rights reserved.

---

## Signature Series Overview

The Signature Series intelligent analog-addressable system from Edwards is an entire family of multi-sensor detectors and mounting bases, multiple-function input and output modules, network and non-network control panels, and user-friendly maintenance and service tools. Analog information from equipment connected to Signature devices is gathered and converted into digital signals. An onboard microprocessor in each Signature device measures and analyzes the signal and decides whether or not to input an alarm. The microprocessor in each Signature device provides four additional benefits – Self-diagnostics and History Log, Automatic Device Mapping, Stand-alone Operation and Fast, Stable Communication.

**Self-diagnostics and History Log** – Each Signature Series device constantly runs self-checks to provide important maintenance information. The results of the self-check are automatically updated and permanently stored in its non-volatile memory. This information is accessible for review any time at the control panel, PC, or using the SIGA-PRO Signature Program/Service Tool. The information stored in device memory includes:

- Device serial number, address, and type
- Time and date of last alarm
- Most recent trouble code logged by the detector — 32 possible trouble codes may be used to diagnose faults.

**Automatic Device Mapping** –The Signature Data Controller (SDC) learns where each device's serial number address is installed relative to other devices on the circuit. The SDC keeps a map of all Signature Series devices connected to it. The Signature Series Data Entry Program also uses the mapping feature. With interactive menus and graphic support, the wired circuits between each device can be examined. Layout or “as-built” drawing information showing branch wiring (T-taps), device types and their address are stored on disk for printing hard copy. This takes the mystery out of the installation. The preparation of as-built drawings is fast and efficient.

Device mapping allows the Signature Data Controller to discover:

- Unexpected additional device addresses
- Missing device addresses
- Changes to the wiring in the circuit.

Most Signature modules use a personality code selected by the installer to determine their actual function. Personality codes are downloaded from the SDC during system configuration and are indicated during device mapping.

**Standalone Operation** – A decentralized alarm decision by the device is guaranteed. Onboard intelligence permits the device to operate in standalone (degrade) mode. If Signature loop controller CPU communications fail for more than four seconds, all devices on that circuit go into standalone mode. The circuit acts like a conventional alarm receiving circuit. Each Signature device on the circuit continues to collect and analyze information from its slave devices. When connected to a panel utilizing standalone operation, modules with their “personality” set as alarm devices (IDC) will alarm should their slave alarm-initiating device activate.



## Input Modules

Models SIGA-CT1, SIGA-CT2 & SIGA-MCT2

### Features

- **MULTIPLE APPLICATIONS**  
Including Alarm, Alarm with delayed latching (retard) for waterflow applications, Supervisory, and Monitor. The installer selects one of four (4) "personality codes" to be downloaded to the module through the loop controller.
- **PLUG-IN (UIO) OR STANDARD 1-GANG MOUNT**  
UIO versions allow quick installation where multiple modules are required. The 1-gang mount version is ideal for remote locations that require a single module.
- **AUTOMATIC DEVICE MAPPING**  
Signature modules transmit information to the loop controller regarding their circuit locations with respect to other Signature devices on the wire loop.
- **ELECTRONIC ADDRESSING**  
Programmable addresses are downloaded from the loop controller, a PC, or the SIGA-PRO Signature Program/Service Tool. There are no switches or dials to set.
- **INTELLIGENT DEVICE WITH MICROPROCESSOR**  
All decisions are made at the module to allow lower communication speed with substantially improved control panel response time and less sensitivity to line noise and loop wiring properties; twisted or shielded wire is not required.
- **NON-VOLATILE MEMORY**  
Permanently stores serial number, type of device, and job number. Automatically updates historic information including hours of operation, last maintenance date, number of alarms and troubles, and time and date of last alarm.
- **STAND-ALONE OPERATION**  
The module makes decisions and inputs an alarm from initiating devices connected to it even if the loop controller's polling interrogation stops. (Function availability dependent upon control panel.)
- **DIAGNOSTIC LEDs**  
Flashing GREEN shows normal polling; flashing RED shows alarm/active state.
- **HIGH AMBIENT TEMPERATURE OPERATION**  
Install in ambient temperatures up to 120°F (49°C).
- **DESIGNED TO ISO 9001 STANDARDS**  
All Signature products are manufactured to strict international quality standards to ensure highest reliability.

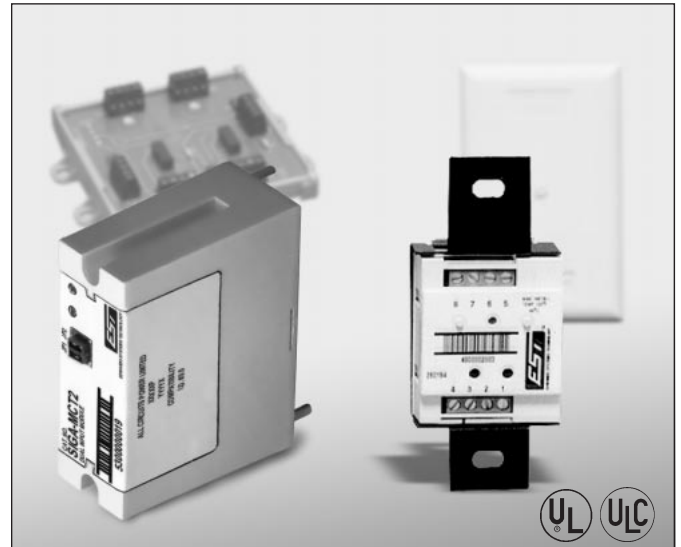

### Description

The SIGA-CT1 Single Input Module and SIGA-CT2/SIGA-MCT2 Dual Input Modules are intelligent analog addressable devices used to connect one or two Class B normally-open Alarm, Supervisory, or Monitor type dry contact Initiating Device Circuits (IDC).

The actual function of these modules is determined by the "personality code" selected by the installer. This code is downloaded to the module from the Signature loop controller during system configuration.

The input modules gather analog information from the initiating devices connected to them and convert it into digital signals. The module's on-board microprocessor analyzes the signal and decides whether or not to input an alarm.

**The SIGA-CT1 and SIGA-CT2** mount to standard North American 1-gang electrical boxes, making them ideal for locations where only one module is required. Separate I/O and data loop connections are made to each module.

**The SIGA-MCT2** is part of the UIO family of plug-in Signature Series modules. It functions identically to the SIGA-CT2, but takes advantage of the modular flexibility and easy installation that characterizes all UIO modules. Two- and six-module UIO motherboards are available. All wiring connections are made to terminal blocks on the motherboard. UIO assemblies may be mounted in EST enclosures.

#### EDWARDS SYSTEMS TECHNOLOGY

SARASOTA, FLA. 941-739-4200 Fax: 941-727-0740  
 CHESHIRE, CT. 203-699-3000 Fax: 203-699-3108  
 OWEN SOUND, CANADA 519-376-2430 Fax: 519-376-7258  
 INTERNATIONAL: CANADA 905-270-1711 Fax: 905-270-9553  
 PITTSFIELD, ME. 207-487-3104

## Installation

**SIGA-CT1 and SIGA-CT2:** modules mount to North American 2½" (64 mm) deep 1-gang boxes and 1½" (38 mm) deep 4" square boxes with 1-gang covers. The terminals are suited for #14 to #18 AWG (1.5 mm<sup>2</sup> to 0.75 mm<sup>2</sup>) wire size.

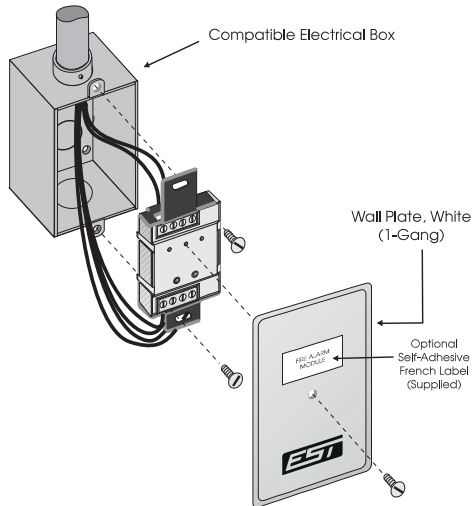

**SIGA-MCT2:** mount the UIO motherboard inside a suitable EST enclosure with screws and washers provided. Plug the SIGA-MCT2 into any available position on the motherboard and secure the module to the motherboard with the captive screws. Wiring connections are made to the terminals on the motherboard (see wiring diagram). UIO motherboard terminals are suited for #12 to #18 AWG (2.5 mm<sup>2</sup> to 0.75 mm<sup>2</sup>) wire size.

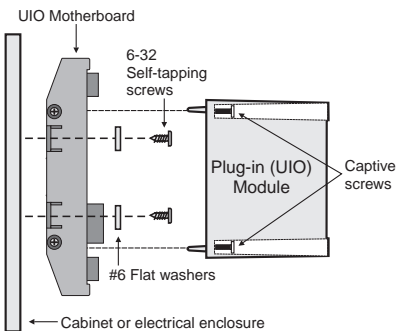

**Electronic Addressing** - The loop controller electronically addresses each module, saving valuable time during system commissioning. Setting complicated switches or dials is not required. Each module has its own unique serial number stored in its on-board memory. The loop controller identifies each device on the loop and assigns a "soft" address to each serial number. If desired, the modules can be addressed using the SIGA-PRO Signature Program/Service Tool.

EST recommends that this module be installed according to latest recognized edition of national and local fire alarm codes.

## Compatibility

The Signature Series modules are compatible only with EST's Signature Loop Controller.

## Application

The duty performed by the SIGA-CT1 and SIGA-CT2/MCT2 is determined by their sub-type code or "Personality Code". The code is selected by the installer depending upon the desired application and is downloaded from the loop controller.

One (1) personality code can be assigned to the SIGA-CT1. Two (2) personality codes can be assigned to the SIGA-CT2/MCT2. Codes 1, 2, 3 and 4 can be mixed on SIGA-CT2/MCT2 modules only. For example, personality code 1 can be assigned to the first address (circuit A) and code 4 can be assigned to the second address (circuit B).

**NORMALLY-OPEN ALARM - LATCHING (Personality Code 1)** - Assign to one or both circuits. Configures either circuit A or B or both for **Class B** normally open dry contact initiating devices such as **Pull Stations, Heat Detectors**, etc. An ALARM signal is sent to the loop controller when the input contact is closed. The alarm condition is latched at the module.

**NORMALLY-OPEN ALARM - DELAYED LATCHING (Personality Code 2)** - Assign to one or both circuits. Configures either circuit A or B or both for **Class B** normally open dry contact initiating devices such as **Waterflow Alarm Switches**. An ALARM signal is sent to the loop controller when the input contact is closed for approximately 16 seconds. The alarm condition is latched at the module.

**NORMALLY-OPEN ACTIVE - NON-LATCHING (Personality Code 3)** - Assign to one or both circuits. Configures either circuit A or B or both for **Class B** normally open dry contact monitoring input such as from **Fans, Dampers, Doors**, etc. An ACTIVE signal is sent to the loop controller when the input contact is closed. The active condition is not latched at the module.

**NORMALLY-OPEN ACTIVE - LATCHING (Personality Code 4)** - Assign to one or both circuits. Configures either circuit A or B or both for **Class B** normally open dry contact monitoring input such as from **Supervisory and Tamper Switches**. An ACTIVE signal is sent to the loop controller when the input contact is closed. The active condition is latched at the module.

## Ordering Information

Catalog Number	Description	Ship Wt. lbs (kg)
SIGA-CT1	Single Input Module - UL/ULC Listed	0.4 (0.15)
SIGA-CT2	Dual Input Module - UL/ULC Listed	0.4 (0.15)
SIGA-MCT2	Dual Input Plug-in (UIO) Module - UL Listed	0.1 (0.05)
Related Equipment		
27193-11	Surface Mount Box - Red, 1-gang	1.0 (0.6)
27193-16	Surface Mount Box - White, 1-gang	1.0 (0.6)
SIGA-UIO2R	Universal Input-Output Module Board w/Riser Inputs - 2 Module Positions	0.32 (0.15)
SIGA-UIO6R	Universal Input-Output Module Board w/Riser Inputs - 6 Module Positions	0.62 (0.28)
SIGA-UIO6	Universal Input-Output Module Board - 6 Module Positions	0.56 (0.25)

# Typical Wiring

Modules will accept #18 AWG (0.75mm<sup>2</sup>), #16 (1.0mm<sup>2</sup>), and #14 AWG (1.50mm<sup>2</sup>) wire sizes. UIO versions will also accept #12 AWG (2.5mm<sup>2</sup>). Note: Sizes #16 AWG (1.0mm<sup>2</sup>) and #18 AWG (0.75mm<sup>2</sup>) are preferred for ease of installation. See Signature Loop Controller catalog sheet for detailed wiring requirement specifications.

Initiating (Slave) Device Circuit Wire Specifications		
Maximum Allowable Wire Resistance	50 ohms (25 ohms per wire) per Circuit	
Maximum Allowable Wire Capacitance	0.1µF per Circuit	
For Design Reference:	Wire Size	Maximum Distance to EOLR
	#18 AWG (0.75 mm <sup>2</sup> )	3,930 ft (1,198 m)
	#16 AWG (1.00 mm <sup>2</sup> )	6,225 ft (1,897 m)
	#14 AWG (1.50 mm <sup>2</sup> )	9,900 ft (3,018 m)

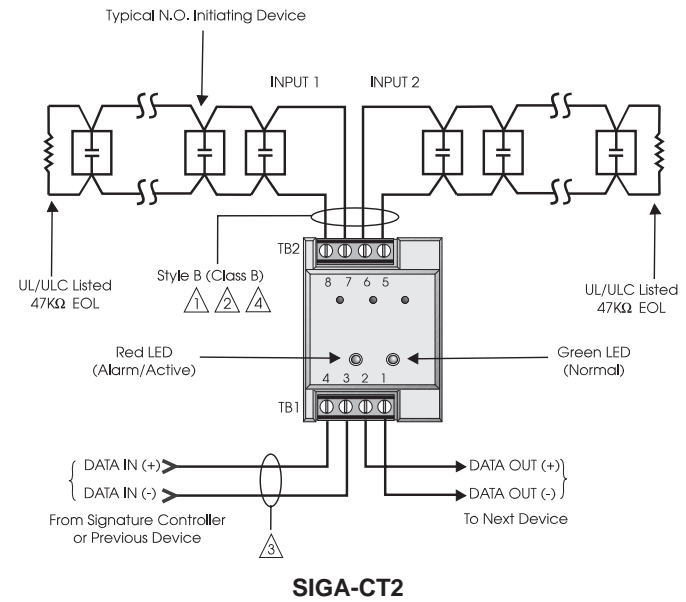
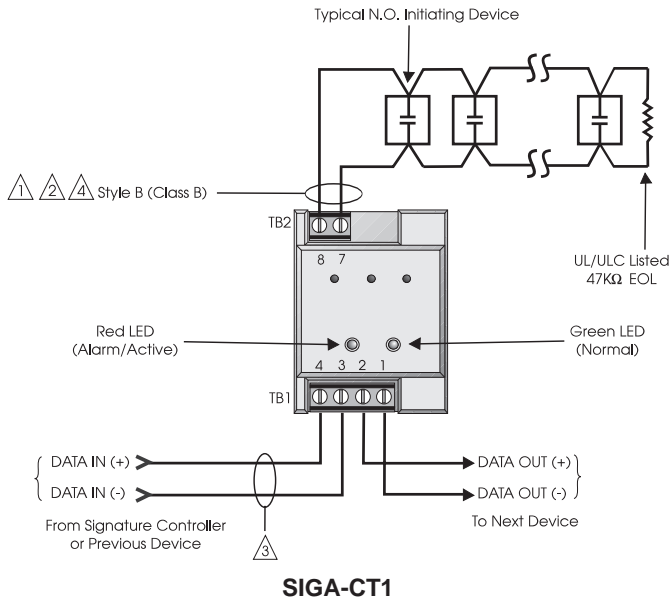

### NOTES

- ① Maximum 25 Ohm resistance per wire.
- ② Maximum #12 AWG (2.5 mm<sup>2</sup>) wire; Minimum #18 AWG (0.75 mm<sup>2</sup>).  
Standard 1-gang version: Maximum #14 AWG (1.5mm<sup>2</sup>) wire. Min. #18 (0.75mm<sup>2</sup>).
- ③ Refer to Signature controller installation sheet for wiring specifications.
- ④ Maximum 10 Vdc @ 350 mA
- ⑤ The SIGA-UIO6R and the SIGA-UIO2R do not come with TB14.
- ⑥ All wiring is supervised and power-limited.
- ⑦ These modules will not support 2-wire smoke detectors.

# Warnings & Cautions

This module will not operate without electrical power. As fires frequently cause power interruption, we suggest you discuss further safeguards with your local fire protection specialist.

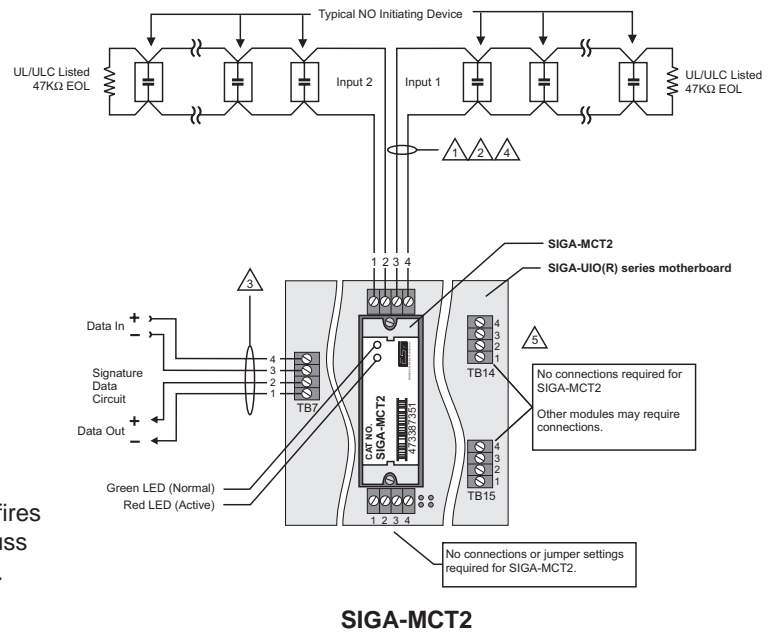

# Specifications

Catalog Number	SIGA-CT1	SIGA-CT2	SIGA-MCT2
Description	Single Input Module		Dual Input Module
Type Code	48 (factory set) 4 sub-types (personality codes) are available		49 (factory set) 4 sub-types (personality codes) are available
Address Requirements	Uses 1 Module Address		Uses 2 Module Addresses
Operating Current	Standby = 250µA; Activated = 400µA		Standby = 396µA; Activated = 680µA
Operating Voltage	15.2 to 19.95 Vdc (19 Vdc nominal)		
Construction	High Impact Engineering Polymer		
Mounting	North American 2½" (64 mm) deep 1-gang boxes and 1½" (38 mm) deep 4" square boxes with 1-gang covers		UIO2R/6R/6 Motherboard
Storage and Operating Environment	Operating Temperature: 32°F to 120°F (0°C to 49°C) Storage Temperature: -4°F to 140°F (-20°C to 60°C) Humidity: 0 to 93% RH		
LED Operation	On-board Green LED - Flashes when polled On-board Red LED - Flashes when in alarm/active Both LEDs - Glow steady when in alarm (stand-alone)		
Compatibility	Use with Signature Loop Controller		
Agency Listings	UL, ULC (See Ordering Table)		

## Description (Signature Overview)

The Signature Series intelligent analog-addressable system from Edwards Systems Technology is an entire family of multi-sensor detectors and mounting bases, multiple-function input and output modules, network and non-network control panels, and user-friendly maintenance and service tools. Analog information from equipment connected to Signature devices is gathered and converted into digital signals. An onboard microprocessor in each Signature device measures and analyzes the signal and decides whether or not to input an alarm. The microprocessor in each Signature device provides four additional benefits – **Self-diagnostics and History Log, Automatic Device Mapping, Stand-alone Operation and Fast, Stable Communication.**

**Self-diagnostics and History Log** – Each Signature Series device constantly runs self-checks to provide important maintenance information. The results of the self-check are automatically updated and permanently stored in its non-volatile memory. This information is accessible for review any time at the control panel, PC, or using the SIGA-PRO Signature Program/Service Tool. The information stored in device memory includes:

- Device serial number, address, and type.
- Date of manufacture, hours of operation, and last maintenance date.
- Number of recorded alarms and troubles.
- Time and date of last alarm.
- Up to 32 possible trouble codes which may be used to specifically diagnose faults.

**Automatic Device Mapping** –The Signature Data Controller (SDC) learns where each device's serial number address is installed relative to other devices on the circuit. The SDC keeps a "map" of all Signature Series devices connected to it. The Signature Series Data Entry Program also uses the mapping feature. With interactive menus and graphic support, the wired circuits between each device can be examined. Layout or "As-Built" drawing information showing branch wiring (T-taps), device types and their address are stored on disk for printing hard copy. This takes the 'mystery' out of the installation. The preparation of "As-Built" drawings is fast and efficient.

Device mapping allows the Signature Data Controller to discover:

- Unexpected additional device addresses.
- Missing device addresses.
- Changes to the wiring in the circuit.

Most Signature modules use a 'personality code' selected by the installer to determine their actual function. Personality codes are

downloaded from the SDC during system configuration and are indicated during device mapping.

**Standalone Operation** – A decentralized alarm decision by the device is guaranteed. Onboard intelligence permits the device to operate in standalone (degrade) mode. If Signature loop controller CPU communications fail for more than 4 seconds, all devices on that circuit go into standalone mode. The circuit acts like a conventional alarm receiving circuit. Each Signature device on the circuit continues to collect and analyze information from its slave devices. When connected to a panel utilizing standalone operation, modules with their 'personality' set as alarm devices (IDC) will alarm should their slave alarm-initiating device activate.

**Fast Stable Communication** – Built-in intelligence means less information needs to be sent between the device and the Signature Data Controller (SDC). Other than regular supervisory polling response, Signature devices only need to communicate with the SDC when they have something new to report. This provides very fast control panel response and allows a lower baud rate (speed) to be used for communication on the circuit. The lower baud rate offers several advantages including:

- Less sensitivity to circuit wire characteristics.
- Less sensitivity to noise glitches on the cable.
- Less emitted noise from the analog wiring.
- Twisted or shielded wiring is not required.

**Diagnostic LEDs** – Twin LEDs on most Signature devices provide visual indication of normal and alarm-active conditions. A flashing green LED shows normal system polling. A flashing red LED means the module is in alarm-active state. Both LEDs on steady indicates alarm-active state – standalone mode.

**Testing & Maintenance** – Automatic self-diagnosis identifies when a Signature device is defective and causes a trouble message. The user-friendly maintenance program shows the current state of each device and other pertinent information. Single devices may be turned off temporarily, from the control panel. **Scheduled maintenance (Regular or Selected) for proper system operation should be planned to meet the requirements of the Authority Having Jurisdiction (AHJ). Refer to current NFPA 72 and ULC CAN/ULC 536 standards.**

**Quality and Reliability** – EST Signature devices are manufactured in North America to strict international ISO 9001 standards. All electronics utilize surface mount technology (SMT) for smaller size and greater immunity to RF noise. A conformal coating is used for humidity and corrosion resistance.

It is our intention to keep the product information current and accurate. We can not cover specific applications or anticipate all requirements. All specifications are subject to change without notice. For more information or questions relative to this Specification Sheet, contact EST.



# Genesis Speakers and Strobes

## Genesis G4 Series

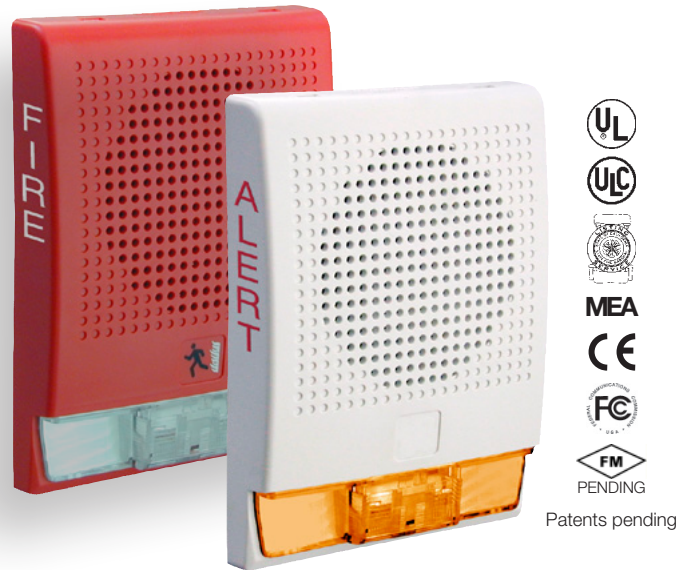

### Overview

The Genesis line of life safety and mass notification/emergency communications (ECS/MNS) signals are the smallest, most compact audible-visible emergency signaling devices in the world. Protruding no more than one inch from the wall, Genesis speakers and speaker-strobes blend with any decor.

Life safety appliances feature textured housings in architecturally neutral white or traditional life safety red.

ECS/MNS appliances offer emergency signaling with clear or amber lenses, white housings, and optional ALERT housing labels. They are ideal for applications that require differentiation between life safety and mass notification signals.

Thanks to patented breakthrough technology, Genesis strobes do not require bulky specular reflectors. Instead, an exclusive design channels and conditions light to produce a highly controllable distribution pattern.

Speaker-strobes feature selectable candela output with a conveniently-located switch on the bottom of the device. The candela setting remains clearly visible even after final installation.

All Genesis speakers include a DC blocking capacitor to allow electrical supervision of the audio distribution circuit. The speaker with its sealed back construction provides extra durability and improved audibility.

### Standard Features

- **Unique low-profile design**
  - The most compact UL/ULC listed speaker-strobe available
  - Ultra-slim, protrudes a mere one inch from the wall
  - Attractive appearance, no visible mounting screws
- **Field configurable – no need to remove the device!**
  - ¼, ½, 1, or 2 watt operation and selectable candela output with convenient switches that remain visible even after the unit is installed
- **ECS/MNS models available**
- **Unparalleled performance**
  - loud 90 dBA output ensures clear, crisp audio
  - Exclusive FullLight strobe technology produces the industry's most even light distribution
  - Precision timing electronics meet tough new synchronizing standards for strobes when used with compatible modules
  - Optional field-configurable temporal strobe output
  - 25 Vrms and 70 Vrms models available, all supplied with a DC blocking capacitor for audio circuit supervision
- **Easy to install**
  - Fits all standard 4" square electrical boxes with plenty of room behind the signal for extra wire – no extension ring or trim plate needed
  - #18 - #12 AWG terminals – ideal for long runs or using existing wiring

## Speaker Application

The suggested sound pressure level for each signaling zone used with alert or alarm signals is a minimum of 15 dB above the average ambient sound level or 5 dB above the maximum sound level having a duration of at least 60 seconds, whichever is greater. This is measured 5 feet (1.5 m) above the floor.

Doubling the distance from the signal to the ear will theoretically cause a 6dB reduction in the received sound pressure level. The actual effect depends on the acoustic properties of materials in the space. Doubling the power output of a device (e.g.: a speaker from 1W to 2W) will increase the sound pressure level by 3dBA.

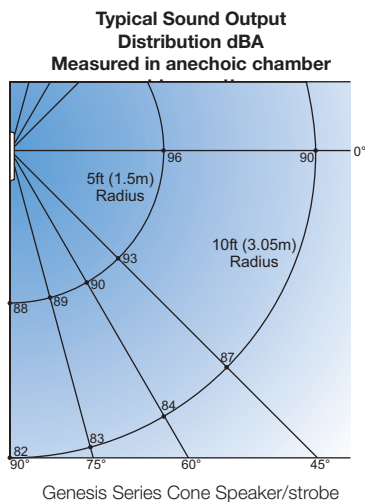

## Installation and Mounting

All models are intended for indoor wall mounted applications only. Speakers and speaker-strobes are flush mounted to a North-American 4" square electrical box, 2<sup>1</sup>/<sub>8</sub>" (54 mm) deep or a European 100 mm square box. Signals may be surface mounted to a Genesis surface-mount box (see ordering information for details).

Two tabs at the top of the signal unlock the cover to facilitate mounting. The shallow depth of Genesis devices leaves room behind the signal for extra wiring. Once installed with the cover in place, no mounting screws are visible.

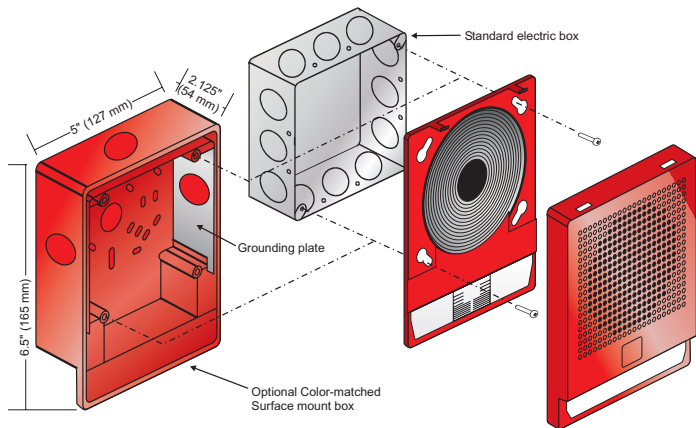

Edwards recommends that these speaker-strobes always be installed in accordance with the latest recognized edition of national and local codes. Refer to installation sheet for mounting height information.

**WARNING:** These devices will not operate without electrical power. As fires frequently cause power interruptions, we suggest you discuss further safeguards with your local fire protection specialist.

## Strobe Application

Genesis clear-lensed strobes are UL 1971-listed for use indoors as wall-mounted public-mode notification appliances for the hearing impaired. Prevailing codes require strobes to be used where ambient noise conditions exceed specified levels, where occupants use hearing protection, and in areas of public accommodation. UL 1638-listed colored-lensed strobe lights are available for ECS/MNS applications. Consult with your Authority Having Jurisdiction for details.

All Genesis strobes meet UL synchronization requirements (within 10 milliseconds over a two-hour period) when used with a synchronization source. Synchronization is important in order to avoid epileptic sensitivity.

### Field Configuration

Genesis speakers may be set for 1/4, 1/2, 1, or 2 watt operation. The wattage setting is visible through a small window on the bottom of the device and is changed by simply sliding the switch until the desired setting appears in the window. The speaker does not have to be removed to change the wattage.

Genesis speaker-strobes feature selectable candela output. The output setting is visible through a small window on the bottom of the device and is changed by simply sliding the switch until the desired setting appears in the window. The speaker-strobe does not have to be removed to change the output.

Use the Candela Switch and the Wattage switch to set desired operation.

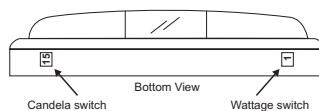

To change strobe to temporal (private mode) cut JP1

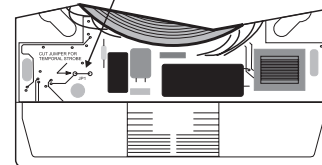

Genesis speaker-strobes may also be configured for temporal flash. This battery-saving feature is intended for private mode signaling only. To set the device for temporal flash, snip the circuit board as shown in the Jumper Locations diagram above.

### ECS/MNS Applications

Genesis ECS/MNS appliances bring the same high-performance life safety features and unobtrusive design to mass notification applications. Standard models are available with clear or amber lenses and optional ALERT housing labels, they are ideal for applications that require differentiation between life safety and mass notification alerts. Appliances with red, green or blue lenses are available. Contact Edwards Customer Service for details.



# Light output

Per cent of UL rating versus angle

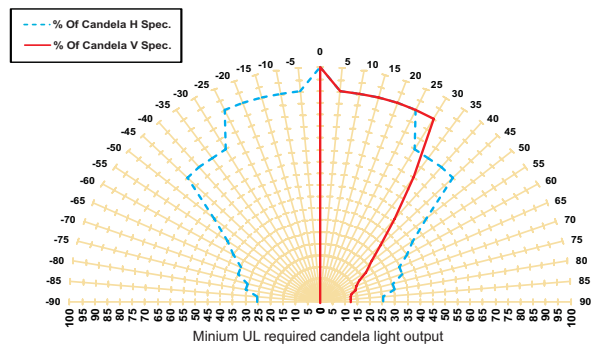

## UL name plate maximum operating current (RMS-mA)

Cd rating	"15" or "A"	"30" or "B"	"75" or "C"	"110" or "D"
16 Vdc	96	130	239	294
16 Vfwr	120	169	329	375

## Typical current, milliamps - average (RMS)

Cd rating	"15" or "A"	"30" or "B"	"75" or "C"	"110" or "D"
20 Vdc	65 (78)	93 (101)	182 (188)	238 (245)
24 Vdc	55 (65)	78 (86)	153 (159)	196 (203)
31 Vdc	45 (53)	63 (69)	120 (124)	151 (157)
20 Vfwr	56 (106)	79 (147)	147 (264)	197 (342)
24 Vfwr	50 (95)	68 (130)	121 (225)	155 (283)
27 Vfwr	44 (84)	60 (115)	107 (200)	137 (251)

Light output switch settings for UL 1971 listed models are selectable by numeric candela value. ECS/MNS appliances are selectable by A, B, C, or D designations.

# Specifications

## Genesis Speakers and Speaker-Strobes

Housing	Red or white textured UV stabilized, color impregnated engineered plastic.
Dimensions	Height: 6.5" (165 mm). Width: 5" (127 mm). Depth to wall: 1" (25 mm).
Mounting (indoor wall mount only)	Flush: North-American 4" square box, 2 1/8" (54 mm) deep. Surface: model G4B (white) or G4RB (red) surface mount box.
Wire Connections	Screw terminals: separate polarized inputs for speaker and strobe, #18 to #12 AWG (0.75 mm <sup>2</sup> to 2.5 mm <sup>2</sup> ) wire size
Operating environment	32-120° F (0-49° C) ambient temperature; 0-93% relative humidity.
Agency Listings	UL 1971, UL 1638, UL 1480, ULC S526, ULC S541, CSFM, MEA (FM pending) (All models comply with ADA Code of Federal Regulation Chapter 28 Part 36 Final Rule.)

## Speakers

Input/Operating Volts	25 VRMS or 70 VRMS. See ordering information.
Speaker Taps/Output*	2 W = 89 dBA; 1 W = 86 dBA; 1/2 W = 83 dBA; 1/4 W = 80 dBA
Speaker Cone	Speaker frequency response: 250 to 5,000 Hz. Optimized for voice intelligibility. 4-inch (102mm) mylar cone, sealed back construction.

## Strobes

Clear Strobe Output Rating	UL 1971, ULC S526: selectable 15 cd, 30 cd, 75 cd, or 110 cd output UL 1971: 15 cd (fixed 15/75 cd models) UL 1638, ULCS526: 75 cd (fixed 15/75 cd models)
Amber Strobe Output Rating	UL 1638: 13 (D), 26 (C), 65 (B), 95 (A)
Strobe Operating Voltage	16 - 33 Vdc Regulated, 16-33 V Full wave rectified (UL Voltage Designations "Regulated 24" and "24 fwr")
Strobe Flash Rate	One flash per second.
Strobe Flash Synchronization	All strobes: one flash per second (fps) within 200 milliseconds over 30 minutes on common circuit. All strobes: Synchronization source required to comply with UL 1971 synchronization standard. Temporal setting (private mode only): synchronized to temporal output on the same circuit.
Synchronization Sources	SIGA-CC1S, SIGA-MCC1S, SIGA-CC2A, SIGA-MCC2A, G1M-RM BPS6A, BPS10A, APS6A, APS10A, iO64, iO500, Fireshield Plus 3, 5 and 10 zone.
Strobe Lens Material	Polycarbonate

\* Measured in reverberant room using 400-4,000 Hz band limited pink noise per UL 1480.

Lens Color	Rating	Switch Position A	Switch Position B	Switch Position C	Switch Position D
Amber	UL 1638	110 cd	75 cd	30 cd	15 cd
Amber	UL 1971*	88 cd	60 cd	24 cd	12 cd
Clear	UL 1971	110 cd	75 cd	30 cd	15 cd

\* Equivalent Rating

## Wiring

Field wiring is connected to Genesis signals with terminals that accommodate #18 to #12 AWG (0.75 mm<sup>2</sup> to 2.5 mm<sup>2</sup>) wiring.

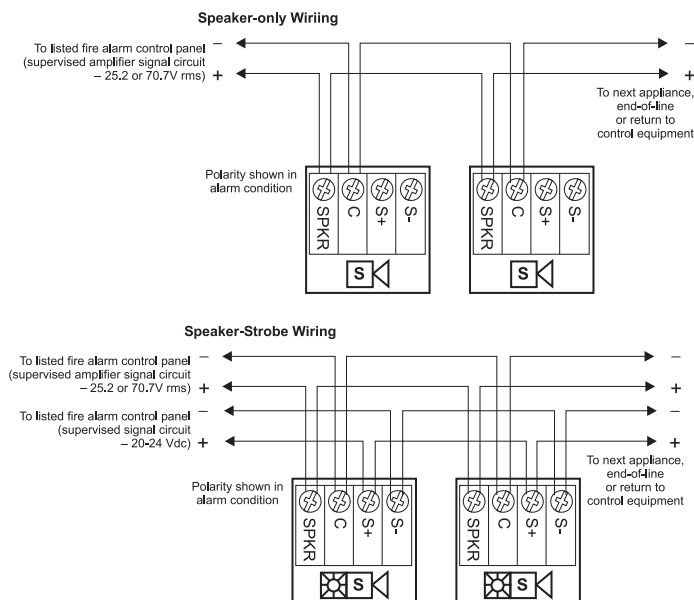



**Detection & alarm since 1872**

U.S.  
T 888 378 2329  
F 866 503 3996

Canada  
Chubb Edwards  
T 519 376 2430  
F 519 376 7258

Southeast Asia  
T : +65 6391 9300  
F : +65 6391 9306

India  
T : +91 80 4344 2000  
F : +91 80 4344 2050

Australia  
T +61 3 9239 1200  
F +61 3 9239 1299

Europe  
T +32 2 725 11 20  
F +32 2 721 86 13

Latin America  
T 305 593 4301  
F 305 593 4300

utcfireandsecurity.com

© 2010 UTC Fire & Security.  
All rights reserved.

## Ordering Information

Light output switch settings for UL 1971 listed models are selectable by numeric candela value.  
ECS/MNS appliances are selectable by A, B, C, or D designations.  
All speaker-strobes include field-selectable ¼, ½, 1, or 2 watt taps

Model	Housing	Marking	Lens	Strobe	Speaker	Ship Wt.
<b>Life safety Appliances (c/w running man icon screen printed on housing)</b>						
G4-S2	White	None	Clear	Selectable 15, 30, 75, or 110 cd	25 Volt	1.5 lbs. (0.68 kg)
G4R-S2	Red	None				
G4F-S2	White	FIRE				
G4RF-S2	Red	FIRE				
G4-S2VM	White	None				
G4R-S2VM	Red	None				
G4F-S2VM	White	FIRE		Selectable 15, 30, 75, or 110 cd	70 Volt	
G4RF-S2VM	Red	FIRE				
G4-S7	White	None				
G4R-S7	Red	None				
G4F-S7	White	FIRE				
G4RF-S7	Red	FIRE				
G4-S7VM	White	None		15/75 cd <sup>1</sup>		
G4R-S7VM	Red	None				
G4F-S7VM	White	FIRE				
G4RF-S7VM	Red	FIRE				
G4F-S7V1575	White	FIRE				
G4RF-S7V1575	Red	FIRE				

<b>ECS/MNS Appliances (no running man icon on housing)</b>							
G4WA-S2VMA	White	Alert	Amber	Selectable A, B, C or D	25 Volt	1.5 lbs. (0.68 kg)	
G4WA-S2VMC		Alert	Clear				
G4WN-S2VMA		None	Amber				
G4WN-S2VMC		None	Clear				
G4WA-S2		Alert	None				Speaker only
G4WN-S2		None	None				
G4WA-S7VMA		Alert	Amber	Selectable A, B, C or D	70 Volt		
G4WA-S7VMC		Alert	Clear				
G4WN-S7VMA		None	Amber				
G4WN-S7VMC		None	Clear				
G4WA-S7		Alert	None				Speaker only
G4WN-S7		None	None				

### Accessories

G1M-RM	Synchronization Output Module (1-gang)	0.2 (0.1)
SIGA-CC1S	Intelligent Synchronization Output Module (2-gang)	0.5 (0.23)
SIGA-MCC1S	Synchronization Output Module (Plug-in UIO)	0.18 (0.08)
G4B	Surface mount box, white	0.7 (0.32)
G4RB	Surface mount box, red	0.7 (0.32)